

## Table of content

<b>1</b>	<b>General Description</b> .....	<b>2</b>
1.1	Applications.....	2
1.2	Mounting Location (Recommendation).....	2
1.3	Function.....	2
1.4	Characteristics.....	2
<b>2</b>	<b>Technical Data</b> .....	<b>3</b>
<b>3</b>	<b>Ordering Information</b> .....	<b>4</b>
3.1	Type Code.....	4
3.2	Currently available Versions.....	4
<b>4</b>	<b>Description of Features according to Type Code</b> .....	<b>5</b>
4.1	Feature 1: Design.....	5
4.2	Feature 2: Connection Ports.....	5
4.3	Feature 3: Input flow rate.....	5
4.4	Feature 4: Maximum Pressure.....	5
4.5	Feature 5: Activation.....	5
4.6	Feature 6: Changeover pressure.....	5
<b>5</b>	<b>Installation</b> .....	<b>6</b>
5.1	General Instructions.....	6
5.2	Connection Proposal.....	6
5.3	Mounting - Mounting Space.....	6
5.3.1	Tightening torque.....	6
5.4	Setting the switching level speed mode - power mode.....	7
5.5	Setting the main spool stroke limitation.....	7
5.6	Dimensions.....	8
<b>6</b>	<b>Notes, Standards and Safety Instructions</b> .....	<b>10</b>
6.1	General Instructions.....	10
6.2	Standards.....	10
<b>7</b>	<b>Accessories</b> .....	<b>10</b>
7.1	Connection plate.....	10

## 1 General Description

By connecting the bottom side to the rod side of a cylinder, the speed can be increased. Speed valves establish this connection and disconnect it under certain operating conditions. Due to the increase in speed, the force of the cylinder is however reduced accordingly.

### 1.1 Applications

Speed valves are used in scrap and concrete shears to achieve short cycle times. The speed mode is only active for the closing operation of the shear. Speed mode is automatically switched off when the full cutting power of the shear is required.

### 1.2 Mounting Location (Recommendation)

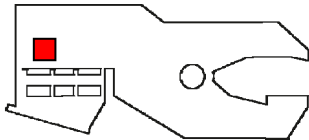

The speed valve is usually mounted directly on the cylinder within the housing of the shear (minimum power losses). But it is also possible to install the speed valve onto a special manifold block outside the attachment.

### 1.3 Function

The valve consists of a main valve which connects either rod side and bottom side (speed mode) or rod side and return line (power mode). The valve is controlled by an integrated pilot valve which switches from speed mode to power mode at an adjustable pressure level at port BS. If power mode is switched, it remains switched due to the hysteresis of the valve until the inlet pressure falls by about 15% of the switching level. A check valve ensures that only low pressure losses occur when the shear is opened. The pilot valve detects rising pressure and switches the main spool of the speed valve from speed mode to power mode. In this switch position the oil is passed from the rod side to the return line at port AS. The volume flow from the main control valve of the machine remains routed to the cylinder bottom side. The pressure now works on the entire area and the maximum working force can be achieved.

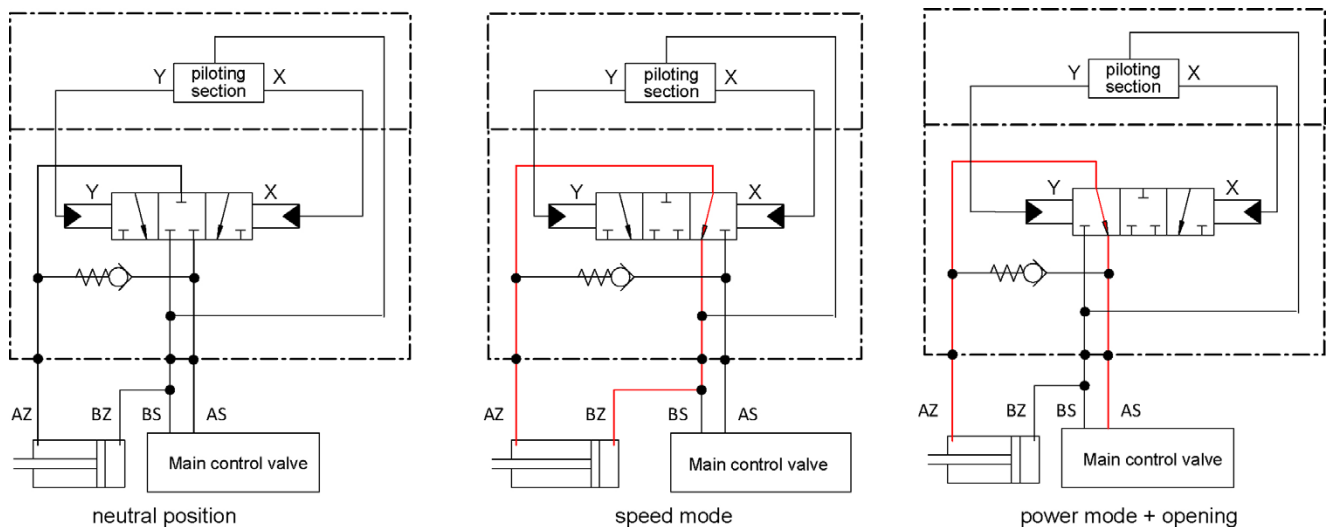

### 1.4 Characteristics

- Automatic switching speed mode - power mode - speed mode
- High switching and functional reliability
- Low power loss in free flow
- Robust valve design, designed for high pressure peaks
- Directly flangeable on the cylinder
- Safety measures against entry and migration of contamination into the piloting section and into the hydraulic system

## 2 Technical Data

Criteria	Unit	Value
Installation position		Any
Weight	kg	250l/min=12,8; 400l/min=22,7; 800l/min=29,0 ; 1000l/min=34,0
Maximum input pressure	bar	320 for construction size 250 l/min, 430 other sizes
Adjustable changeover pressure regen mode → power mode	bar	250 to 300 - factory setting: 270
Fall back level power mode → regen mode	bar	falls by about 15% of the switching level, regen mode → power mode
Maximum input flow rate	l/min	Depending on construction size 250; 400; 800; 1000
Maximum recommended return pressure (AS)	bar	<30 for construction size 250 l/min, < 80 for other sizes
Hydraulic fluid		Mineral oil (HL, HLP) conforming with DIN 51524, other fluids upon request
Hydraulic fluid pressure range	°C	-20 to +80
Ambient temperature	°C	< +50
Viscosity range	mm <sup>2</sup> /s	2.8 - 500
Contamination grade		Filtering conforming with NAS 1638, class 9, with minimum retention rate $\beta_{10} \geq 75$

### 3 Ordering Information

#### 3.1 Type Code

REG	2D					270		
00	01	02	03	04	05	06	07	
00	Product group	Regenerative valves						<b>REG</b>
01	Variant	Standard construction form for differential cylinder, generation 2						<b>2D</b>
02	Construction size	flange connection	250 l/min bore hole diameter 21,0 mm					<b>996</b>
			400 l/min bore hole diameter 27,0 mm					<b>997</b>
			800 l/min (links) bore hole diameter 35,0 mm					<b>998</b>
			800 l/min (rechts) bore hole diameter 35,0 mm					<b>993</b>
			1000 l/min bore hole diameter 40,0 mm					<b>999</b>
03	Input flow rate	Port 996: 250 l/min					<b>0250</b>	
		Port 997: 400 l/min					<b>0400</b>	
		Port 993 & 998: 800 l/min					<b>0800</b>	
		Port 999: 1000 l/min					<b>1000</b>	
04	Max. permissible pressure	320 bar (only at port 996 and 997)					<b>320</b>	
		420 bar					<b>420</b>	
05	Activation	Automatic changeover at adjustable changeover pressure						<b>000000</b>
06	Changeover pressure	Changeover from regen mode to power mode, standard setting 270bar,						<b>XXX</b>
07	Connection plate / flangeable	Connection plate available port 996 and 997						<b>AP</b>
		Flangeable directly on the cylinder						<b>FL</b>

XXX – fixed features    XXX – customer selectable features    ■ available    ○ not available

Some theoretical configurations might be not feasible for technical reasons. For relating questions please ask for our advice.

#### 3.2 Currently available Versions

The versions listed below are available standard-versions. Further versions in the range of the above mentioned features are available on request.

Designation	Type code	Part No.
REG-2D 250LPM 320BAR 270BAR FLANGE	REG -2D -996 -250 -320 -000000 -270 -FL	136.914.307.9
REG-2D 400LPM 420BAR 270BAR FLANGE	REG -2D -997 -400 -420 -000000 -270 -FL	137.914.324.9
REG-2D 400LPM 420BAR 270BAR ADAPTER PLATE	REG -2D -05E -400 -420 -000000 -270 -AP	137.914.325.9
REG-2D 800LPM 420BAR 270BAR FLANGE	REG -2D -998 -800 -420 -000000 -270 -FL	138.914.315.9
REG-2D 1000LPM 320BAR 270BAR FLANGE	REG -2D -999 -999 -420 -000000 -270 -FL	139.914.305.9

## 4 Description of Features according to Type Code

### 4.1 Feature 1: Design

The valve is suited to operate differential cylinders in regen mode (cylinder bottom side and cylinder rod side are connected) or in power mode (cylinder bottom side and cylinder rod side are not connected). A separate tank or leakage-oil connection is not necessary. The valve is designed for back pressures of up to 80 bar.

### 4.2 Feature 2: Connection Ports

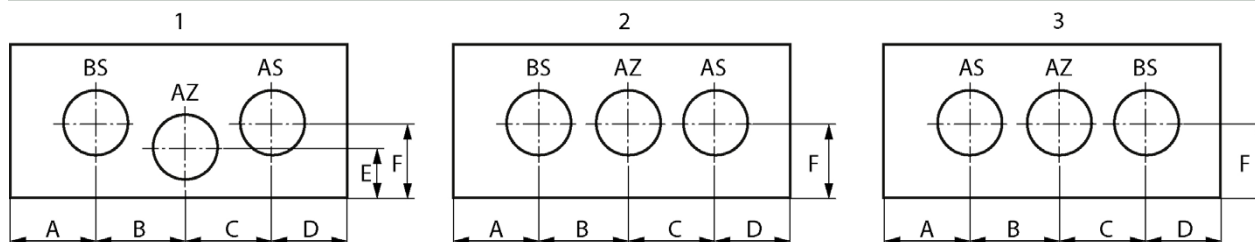

View on the speed valve

Connections	1 Construction size 996 (250 l/min)	1 Construction size 997 (400 l/min)	2 Construction size 993 3 Construction size 998 (800 l/min)	3 Construction size 999 (1000 l/min)
AS, AZ, BS	D 21.0	D 27.0	D 35.0	D 40.0
MX, MY, MAS, MBS, MAZ	Minimes M8x1		7/16 – 20 UNF	
<b>Measurement</b>				
A	56	66	40	58
B	30	39	60	57
C	30	39	60	57
D	55	56	40	58
E	37	43	70	70
F	53	57	70	70

### 4.3 Feature 3: Input flow rate

The maximum input flow rate for the different construction sizes is:

Construction size	Max. input flow rate [l/min]
996	250
997	400
993, 998	800
999	1000

Input flow rate means: the volume flow that is supplied from the machine in both directions to the attachment.

### 4.4 Feature 4: Maximum Pressure

The maximum permissible pressure at the inputs and the outputs of the regenerative valve is 420 bar, For construction size 250 l/min, the maximum pressure is 320 bar.

### 4.5 Feature 5: Activation

The switching of the regenerative valve from regen mode to power mode takes place automatically when a certain, adjustable pressure is exceeded in the bottom side of the connected cylinder. See Characteristic 6: Changeover pressure

### 4.6 Feature 6: Changeover pressure

If the pressure in the bottom side of the cylinder (port BS) exceeds the adjustable changeover pressure the valve switches from regen to power mode. It switches back if the pressure falls by approx. 10% of the switching level.

## 5 Installation

### 5.1 General Instructions

- Only technically permitted changes are to be made on the construction machine.
- The user has to ensure that the device is suitable for the respective application.
- Application exclusively for the range of application specified by the manufacturer.
- Before installation or dismantling, the hydraulic system is to be depressurized.
- Settings are to be made by qualified personnel only.
- May only be opened with the approval of the manufacturer, otherwise the warranty is invalidated.
- Installation recommendations is without liability, functionality and the technical details of the construction machine must be checked.

### 5.2 Connection Proposal

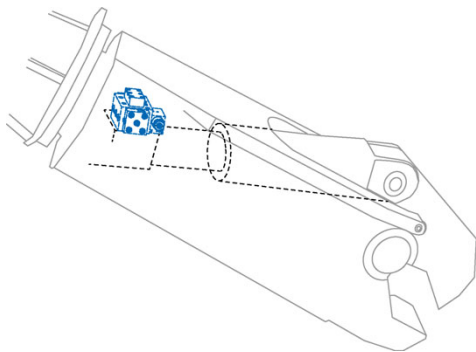

- The regenerative valve is installed on the cylinder flange surface of the cylinder.
- The supply connection from the main control block for the rod side is thus connected with the AS connection.
- The AZ connection is connected with the cylinder connection on the rod side.
- The BS connection also comes from the control block and the BZ connection is connected with the bore side of the cylinder.
- Ensure that the flange surface is level

### 5.3 Mounting - Mounting Space

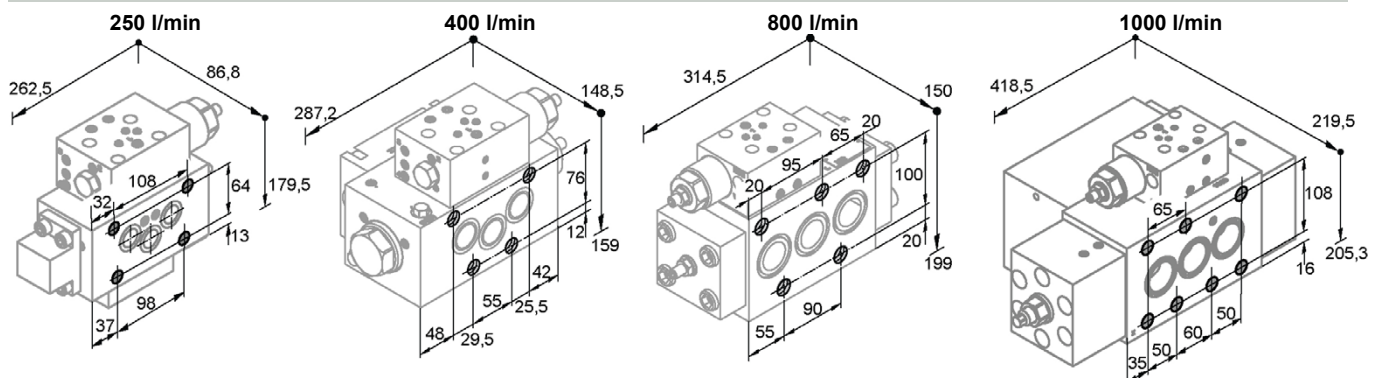

#### 5.3.1 Tightening torque

	Thread A	Strength class	Thread depth B	Tightening torque Nm	C mm
<b>Mounting bolts</b> Construction size 996 (250 l/min)	M14	12,5		150	30
<b>Mounting bolts</b> Construction size 997 (400 l/min)	M16	12,5		250	109
<b>Mounting bolts</b> Construction size 993, 998 (800 l/min)	M20	12,5		500	109
<b>Mounting bolts</b> Construction size 999 (1000 l/min)	M18	12,5		250	109

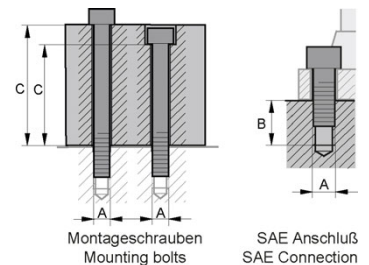

**Attention:** Tightening torques must be observed. Torque wrench needed. In counterpart the sufficient screw depth must be ensured.

#### 5.4 Setting the switching level speed mode - power mode

The piloting valve determines the pressure level for switching from speed mode to power mode. Depending on the customer needs this level is set between 250 and 300 bar. The aim is to stay as long as possible in speed mode in order to keep the cycle times short.

NOTE: The lock nut (1) must be replaced after being used five times.

The level can be set as follows:

- Make sure that the system is not under pressure
- undo the lock nut (1)
- Setting the switching pressure with set screw (2)  
NOTE: 1/8 turn increases / decreases the switchover level by approximately \_\_\_\_ bar  
Increase switchover level: turn adjustment screw (2) by 1/8 turns clockwise  
Reduce switchover level: turn adjustment screw (2) by 1/8 turns anticlockwise
- tighten locknut (1)
- Check cutting result and, if necessary, correct setting by another 1/8 turn

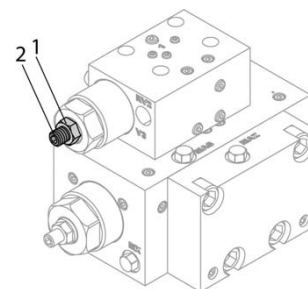

#### 5.5 Setting the main spool stroke limitation

When the cylinder is being extended the main spool of the speed valve must immediately turn into speed mode. For this purpose, the inlet pressure is applied to the left side of the spool. On the right side of the spool the return pressure affects. With low return line diameters or positive overlapping of the main control valve spool, it is possible that due to the pressure intensification in the cylinder the return pressure is similar or even higher than the inlet pressure. In this case, the speed valve directly switches into the power mode.

To prevent this effect, an additional pressure loss can be produced at the control edge AZ-AS of the valve by activating a stroke limitation which increases the inlet pressure and thereby the switching pressure but not increases the return pressure which would counteract to the switching capability.

NOTE: A stroke limitation which is screwed in too far, will produce an unnecessary high loss.

- Make sure that the system is not under pressure
- Loosen the lock nut (1)
- Set stroke limitation with adjusting screw (2)  
Increase pressure loss: turn adjustment screw (2) by 1/8 turns clockwise  
Reduce pressure loss: turn adjustment screw (2) by 1/8 turns counterclockwise
- tighten locknut (1)
- Verify that the speed valve switches properly and, where appropriate, set a further 1/8 of a turn

NOTE: If the speed valve switches properly yet turn the bolt an additional 1/8 turn.

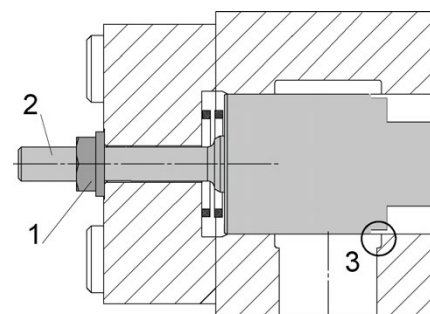

5.6 Dimensions

construction size 250 l/min

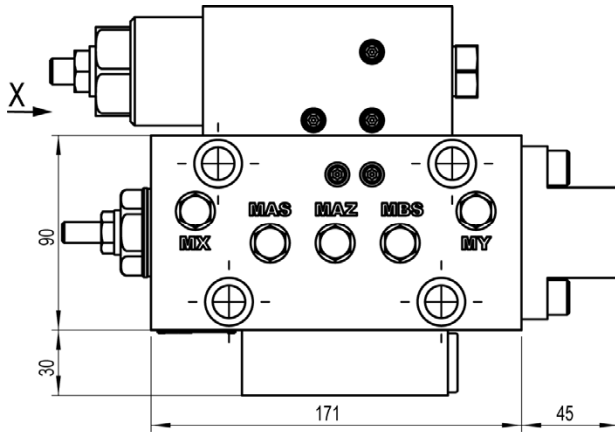

construction size 400 l/min

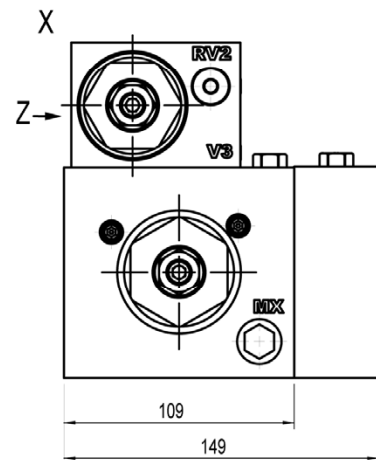
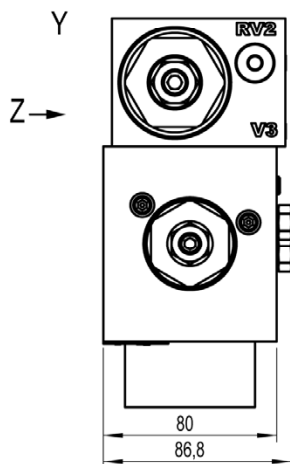
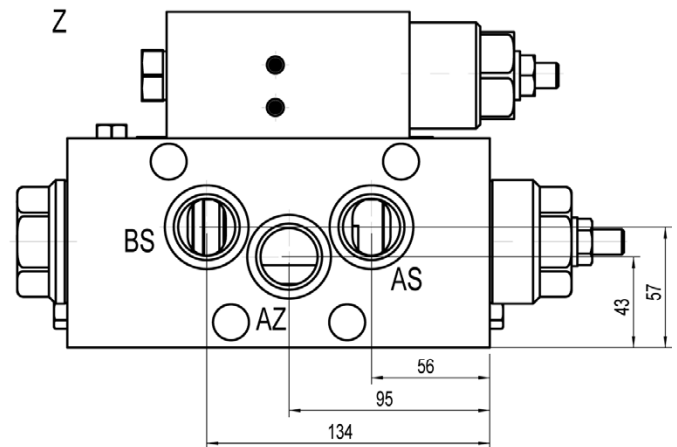
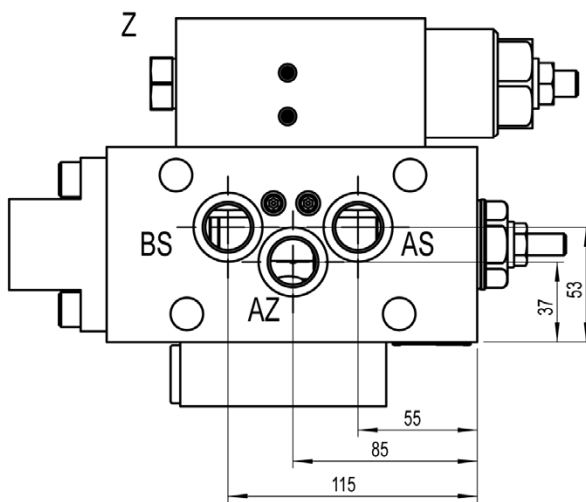
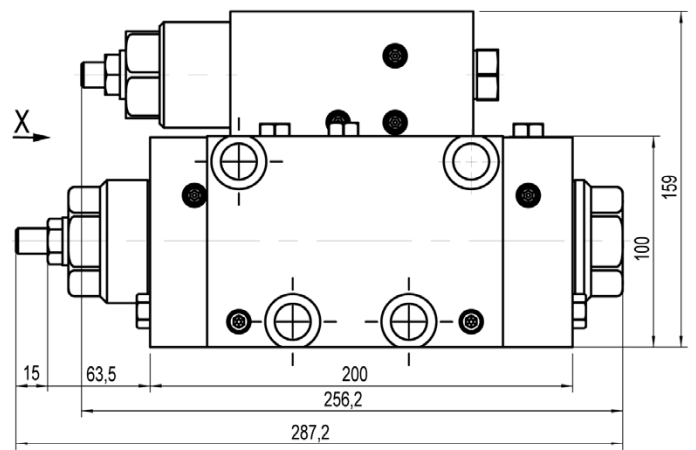

construction size 800 l/min Version left  
(mirrored right version)

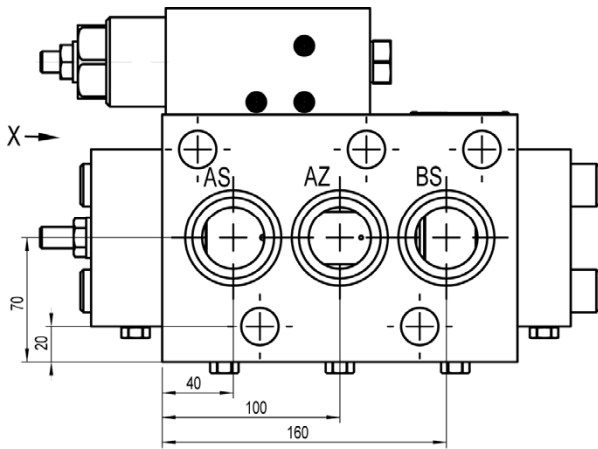

construction size 1000 l/min

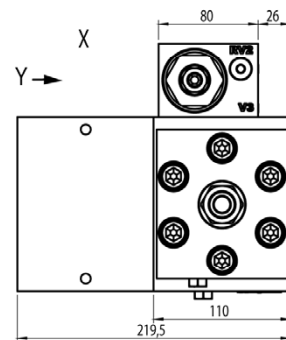
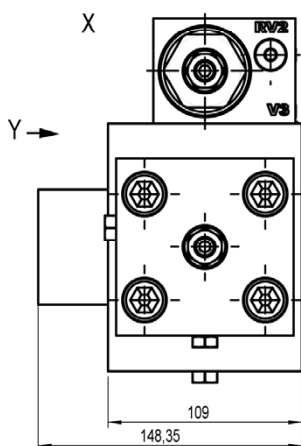
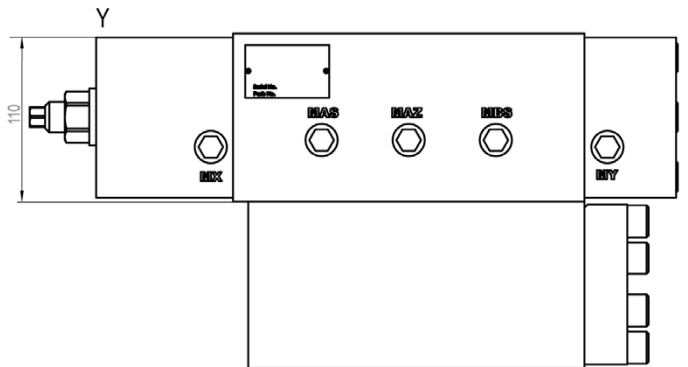
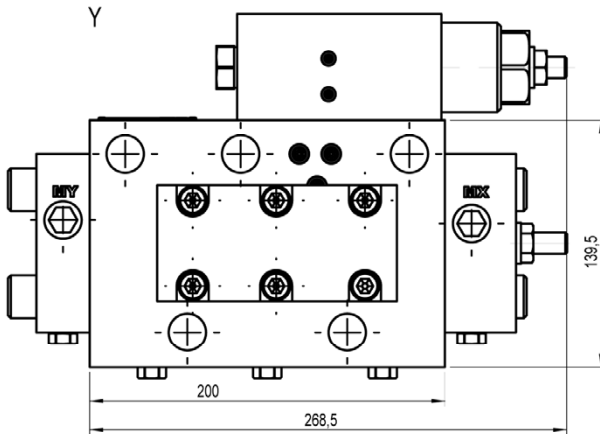
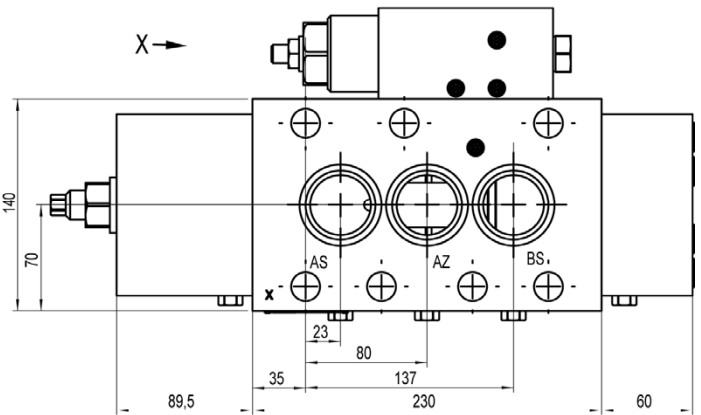

## 6 Notes, Standards and Safety Instructions

### 6.1 General Instructions

- The views in drawings are shown in accordance with the European normal projection variant

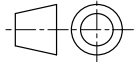

- A comma ( , ) is used as a decimal point in drawings
- All dimensions are given in mm

### 6.2 Standards

The following standards must be observed when installing and operating the valve:

- DIN EN ISO 13732-1:2008-12, Temperatures on accessible surfaces

## 7 Accessories

### 7.1 Connection plate

The regenerative valve is normally flanged directly onto the cylinder (3 connections). For use with a non-fitting cylinder flange, the regenerative valve is optionally offered with a connection plate (4 connections). Only at port 996 and 997

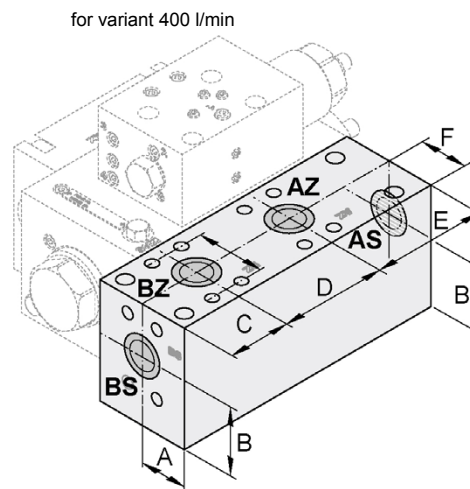
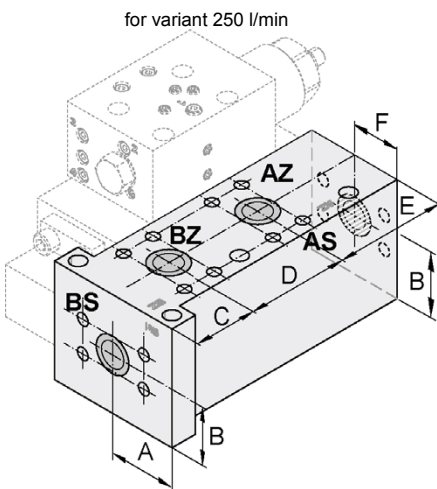

Measurement	Construction size 996 (250 l/min)	Construction size 997 (400 l/min)
AS, AZ, BS, BZ	SAE 1"	SAE 1"
A	55	40
B	48	57
C	52	52
D	83	88
E	91	95
F	40	40
G	D 25,0	D 25,0

	Thread A	Strength class	Thread depth B	Tightening torque Nm	C mm
SAE 1"	M12	8.8	22	92	
Mounting bolts	4x M12	8.8		84	96 (250 l/min) 99,5 (400 l/min)

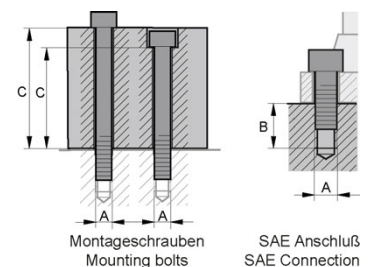

**Attention:** Tightening torques must be observed. Torque wrench needed. In counterpart the sufficient screw depth must be ensured.

The versions listed below are available standard-versions. Further versions in the range of the above mentioned features are available on request.

Designation	Type code	Part No.
REG-2D 250LPM 320BAR 270BAR ADAPTER PLATE	REG -2D -996 -250 -320 -000000 -270 -AP	136.914.309.9
REG-2D 400LPM 420BAR 270BAR ADAPTER PLATE	REG -2D -05E -400 -420 -000000 -270 -AP	137.914.325.9