

## Table of Contents

<b>1</b>	<b>Product Description</b> .....	<b>2</b>
1.1	Application .....	2
1.2	Mounting location .....	2
<b>2</b>	<b>Function</b> .....	<b>3</b>
2.1	Characteristics .....	3
2.2	Adjustment options .....	3
<b>3</b>	<b>Technical Data</b> .....	<b>4</b>
3.1	General .....	4
3.2	Hydraulics .....	4
<b>4</b>	<b>Ordering Information</b> .....	<b>5</b>
4.1	Type code .....	5
4.2	Versions currently available .....	6
<b>5</b>	<b>Description of Characteristics in Accordance with Type Code</b> .....	<b>7</b>
5.1	Characteristic 1: Variant.....	7
5.2	Characteristic 2: Connections .....	7
5.3	Characteristic 3: Spool.....	7
5.4	Characteristic 4: Pressure setting .....	7
5.5	Characteristic 5: Actuation .....	7
5.6	Characteristic 6: Opening pressure .....	7
5.7	Characteristic 7: Setting compensation .....	7
5.8	Characteristic 8: Lowering speed adjustable .....	7
<b>6</b>	<b>Installation</b> .....	<b>8</b>
6.1	General remarks .....	8
6.2	Connection recommendations .....	8
6.3	Installation - space .....	9
6.4	Setting "opening pressure" .....	9
6.4.1	Setting opening start version 1 .....	9
6.4.2	Setting opening start version 2 .....	9
6.5	Setting Pressure limitation .....	10
6.6	Setting Maximum lowering speed .....	10
<b>7</b>	<b>Dimensions</b> .....	<b>11</b>
7.1.1	Dimensions LHB-3N .....	11
7.1.2	SAE dimensions.....	12
<b>8</b>	<b>Notes, Standards and Safety Requirements</b> .....	<b>12</b>
8.1	General remarks .....	12
8.2	Standards.....	12
8.3	Safety requirements.....	12
<b>9</b>	<b>Accessories</b> .....	<b>12</b>

## 1 Product Description

In case of a pipe or tube rupture load control valves avoid uncontrolled movement of the cylinder. In some countries these valves are required by law when a construction machine is used for load lifting purposes. They also serve for an exact and stable positioning of the boom and enable sensitive and even movement processes. Load control valves can compensate for leakages on the main control valves in older construction machines. WESSEL load control valves stand for an excellent sensitivity and a very direct response to the handle's stroke. In any case they are leakage free.

The design of this load control valve is standard and can fit most of the standard applications.

### 1.1 Application

Applications: Boom- stick- and bucket cylinders in excavators

### 1.2 Mounting location

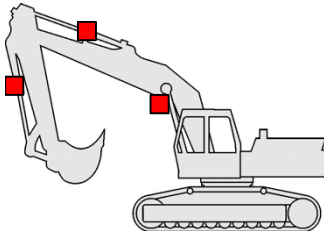

The load control valve is installed in the line to be protected between the main control valve and the hydraulic cylinder and is flanged directly on the cylinder. Additional pipework and piping between load control valve and cylinder is not permissible.

## 2 Function

The Load Holding Valve is closed and leakage free in its unpiloted position. When deploying the cylinder, the hydraulic fluid is fed to the cylinder via a check valve.

Pilot control pressure in the VSt connection uses control surfaces to open the Load Holding Valve piston against a pressure spring and introduces a jolt-free lowering movement. As the pilot control pressure continues to increase, the entire control cross-section of the Load Holding Valve piston is released and the maximum lowering speed is reached. If a hose or pipe breaks, the Load Holding Valve controls the maximum lowering speed to the setting defined with the control lever and the maximum specified lowering speed is not exceeded. By moving the control lever into its neutral position further lowering is prevented. The Load Holding Valve piston is load-compensated so that no closing force from the return pressure affects the Load Holding Valve piston. The secondary valve is connected with connection Z and opens up to connection VSt when the defined maximum pressure is achieved, which opens the Load Holding Valve piston and allows pressure to be decreased from Z to St. A pressure limiting valve is required if the main directional control valve has a closed central position.

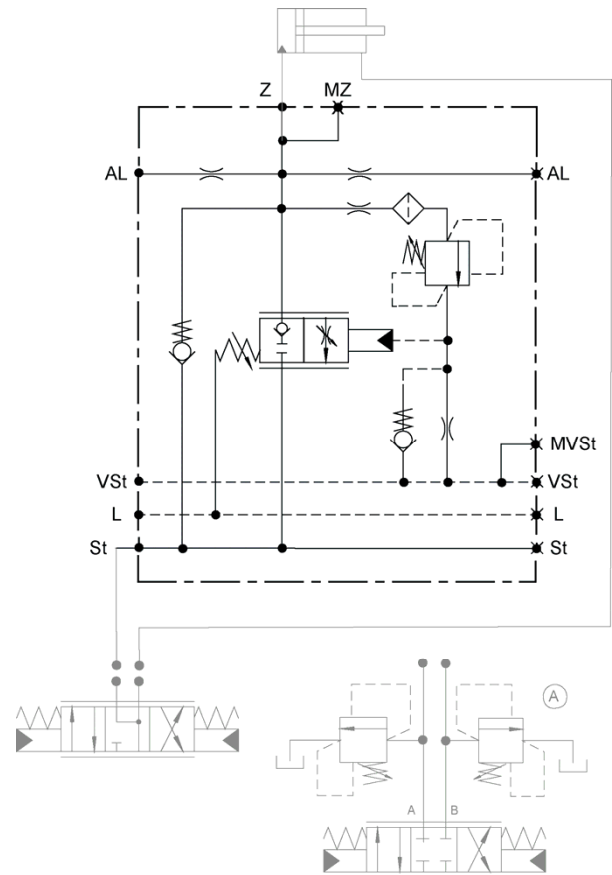

### 2.1 Characteristics

- Meets the requirements of standards: DIN24093, ISO 8643, EN 474
- Start opening independent of the load pressure
- Sensitive control with low hysteresis
- Leakage-free
- Load control valve piston pressure-compensated
- Symmetrical connections to/from the control valve on the right and the left side of the load control valve
- Can be flanged directly onto the cylinder connection
- Surge line for parallel operation for the minimization of the cylinder pressure differences with construction size SAE 1"
- Pressuring limiting valve with upstream filter sieve for protecting the cylinder

### 2.2 Adjustment options

- Opening Start of the Load Control Valve
- Opening Start of the Pressure Limiting Valve Adjustable
- Lowering Speed Limiting Adjustable (optional)

### 3 Technical Data

#### 3.1 General

Criterion		Units	Value				
Z, ST			SAE 1/2"	SAE 3/4"	SAE 1"		
			(DIN ISO 6162-2, SAE J518/2 (CODE62)) <b>ST=G1/2</b>	(DIN ISO 6162-1, SAE J518/1 (CODE61))	(DIN ISO 6162-2, SAE J518/2 (CODE62))	(DIN ISO 6162-1, SAE J518/1 (CODE61))	(DIN ISO 6162-2, SAE J518/2 (CODE62))
Max. operating pressure	bar	420	350	420	350	420	
Range pressure setting	bar	250 – 420	250 – 350	250 – 420	250 – 350	250 – 420	
Pressure setting		See type code feature 04: Pressure setting					
Max. volume flow		See type code feature 03: Spool					
Weight	kg	4.2	9.1	9.1	13.2	13.2	
Opening pressure	bar	6 - 10					
Full opening	bar	Opening pressure + leak oil pressure + 17					
<b>Connection</b>	<b>Connection sizes</b>		<b>Pmax</b>	<b>Pmax</b>	<b>Pmax</b>	<b>Pmax</b>	<b>Pmax</b>
Vst, MVst	G 1/4 ISO 1179-1	bar	50	50	50	50	50
Al, MZ, MSt	G 1/4 ISO 1179-1	bar	420	350	420	350	420
L	G 1/4 ISO 1179-1	bar	< 0.5	< 0.5	< 0.5	< 0.5	< 0.5
Installation position		Any					

#### 3.2 Hydraulics

Criterion	Units	Value
Hydraulic fluid		Mineral oil (HL, HLP) conforming with DIN 51524, other fluids upon request
Hydraulic fluid temperature range	°C	-20 – +80
Ambient temperature:	°C	< +50
Viscosity range	mm <sup>2</sup> /s	2.8 – 500
Contamination grade		Filtering conforming with NAS 1638, class 9, with minimum retention rate $\beta_{10} \geq 75$

## 4 Ordering Information

### 4.1 Type code

<b>LHB</b> 00	<b>3N</b> 01				<b>HYP 03B</b> 05		<b>00</b> 07		
00	Product group	Load Control Valve Boom							<b>LHB</b>
01	Variant	Step variant							<b>3N</b>
02	Connections	Cylinder	SAE 1/2" – (DIN ISO 6162-2, SAE J518/2 (CODE62))						<b>05A</b>
			SAE 3/4" – (DIN ISO 6162-1, SAE J518/1 (CODE61))						<b>04C</b>
			SAE 3/4" – (DIN ISO 6162-2, SAE J518/2 (CODE62))						<b>05C</b>
			SAE 1" – (DIN ISO 6162-1, SAE J518/1 (CODE61))						<b>04E</b>
			SAE 1" – (DIN ISO 6162-2, SAE J518/2 (CODE62))						<b>05E</b>
03	Spool	Design of the spool optimized for the specified volume flow; [l/min]	Only version SAE 1/2"						<b>100</b>
			Versions SAE 1/2" and 3/4"						<b>150</b>
			Only version SAE 3/4"						<b>200</b>
			Versions SAE 3/4" and 1"						<b>250</b>
			Only version SAE 1"						<b>300</b>
04	Pressure setting	Pressure limiting valve opens at a volume flow of 10 l/min	200 bar to 420 bar, Standard 420 bar						<b>XXX</b>
05	Actuation	Hydraulically proportional, connection G1/4							<b>HYP 03B</b>
06	Opening pressure	Load control valve opens at a pilot control pressure as of 6 bar to 10 bar, Standard 8 bar = 008							<b>XXX</b>
07	Setting compensation	No compensation							<b>00</b>
08	Maximum lowering speed adjustable	No							<b>0</b>
		Yes							<b>1</b>

XXX – permanently predetermined characteristics    XXX – characteristics selectable by customer    ■ available    ○ not available  
Different configurations are unfortunately not implementable for technical reasons. Please let us know if you have questions.

#### 4.2 Versions currently available

The versions listed below are available as standard. Further versions as part of the options given on the type code can be configured upon request.

00	01	02	03	04	05	06	07	08	Name	Part No.
LHB	3N	04C	250	210	HYP03B	008	00	0	LHB-3N SAE3/4 CD61 250LPM 210BAR 8BAR NO SPEED ADJ	426.063.955.9
LHB	3N	05C	250	420	HYP03B	008	00	0	LHB-3N SAE3/4 CD62 250LPM 420BAR 8BAR NO SPEED ADJ	426.063.956.9
LHB	3N	05C	300	420	HYP03B	008	00	1	LHB-3N SAE3/4 CD62 300LPM 420BAR 8BAR SPEED ADJ	426.063.964.9
LHB	3N	05E	300	420	HYP03B	008	00	0	LHB-3N SAE1 CD62 300LPM 420BAR 8BAR NO SPEED ADJ	427.063.956.9
LHB	3N	04E	300	210	HYP03B	008	00	0	LHB-3N SAE1 CD61 300LPM 210BAR 8BAR NO SPEED ADJ	427.063.961.9
LHB	3N	05E	300	420	HYP03B	010	00	1	LHB-3N SAE1 CD62 300LPM 420BAR 10BAR SPEED ADJ	427.063.965.9
LHB	3N	05E	200	420	HYP03B	008	00	0	LHB-3N SAE1 CD62 200LPM 420BAR 8BAR NO SPEED ADJ	427.063.982.9
LHB	3N	04E	300	350	HYP03B	008	00	1	LHB-3N SAE1 CD61 300LPM 350BAR 8BAR SPEED ADJ	427.063.990.9

## 5 Description of Characteristics in Accordance with Type Code

### 5.1 Characteristic 1: Variant

Stepped housing

### 5.2 Characteristic 2: Connections

The valves are flanged directly on the cylinder to be protected (connection Z). The supply line from the control valve takes place via the connection ST. As a rule, both connections are designed the same.

### 5.3 Characteristic 3: Spool

The control slider is calculated to the maximum desired volume flow (Z → ST). Criterion: Nominal volume flow, in which a pressure loss ( $\Delta p$ ) of maximum 50 bar is generated (Z → ST)

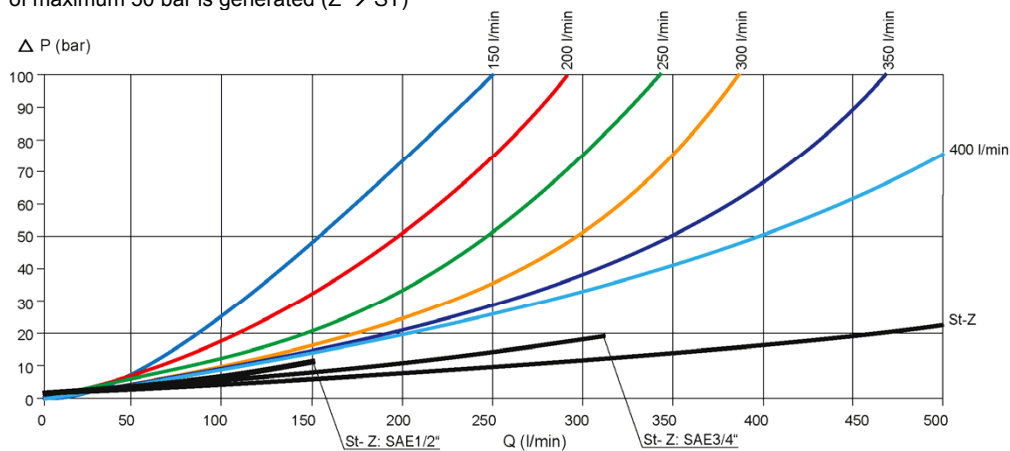

### 5.4 Characteristic 4: Pressure setting

Setting of the pressure restriction valve for protecting cylinder (connection Z).  
The operating pressure of the valve at input ST and output Z must not exceed 420 bar for all versions.

### 5.5 Characteristic 5: Actuation

Actuation type of the valve and connection size of the pilot control connection.  
Standard actuation type is "hydraulically proportional".

### 5.6 Characteristic 6: Opening pressure

Level of the pilot control pressure (connection VST), in which the valve opens and the cylinder begins its lowering movement.

### 5.7 Characteristic 7: Setting compensation

Compensation of the impact of load pressure on the lowering speed. The setting is performed in the factory and cannot be changed.

No compensation

The load pressure had no impact on the opening cross-section of the hose rupture valve.

Higher load pressure – higher lowering speed

### 5.8 Characteristic 8: Lowering speed adjustable

In addition to the design of the control spool for a maximum volume control, the lowering speed can be further limited by this setting.





### 6.3 Installation - space

- Observe the connection labels
- Observe the strength category and torsional torque of the clamp bolts
- Do not damage seals and flange surface
- The air must be exhausted from the hydraulic system
- Observe the recommended installation screws

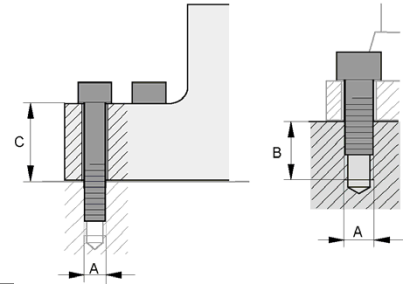

Thread (A)	Strength class	Thread depth (B)	Tightening torque (Nm)	C (mm)
DIN ISO 6162-1, SAE J518/1 (CODE61)				
M10x1.5	10.9	16.5	70	SAE 3/4" = 35
M10x1.5	10.9	21	70	SAE 1" = 38
DIN ISO 6162-2, SAE J518/2 (CODE62)				
M8x1.25	10.9	13.5	36	SAE 1/2" = 26
M10x1.5	10.9	16.5	70	SAE 3/4" = 35
M12x1.75	10.9	21.5	130	SAE 1" = 38

### 6.4 Setting "opening pressure"

The opening pressure of the load control valve is set in the factory according to type code. A setting during startup is not necessary and, for safety purposes, may only be performed by trained technicians using suitable measuring equipment.

The setting of the opening pressure, that is the level of the pilot control pressure, from which the load control valve opens to lower the cylinder, is set on the spring cap unit. Depending on the manufacture date of the hose rupture valve, there are two versions of the setting in the cycle:

#### 6.4.1 Setting opening start version 1



**ATTENTION**

During operation, the valve can heat up to the oil temperature.

- Loosen the counternut AF32 (1).
- The opening pressure of the load control valve must be approximately 0.5 bar above the opening start of the main control unit spool.
- Increase: Turn the set-screw AF8 (2) clockwise.
- Decrease: Turn the set-screws AF8 (2) counter-clockwise.
- 1 revolution corresponds with 3 bar
- Tighten the counternut AF32 (1).

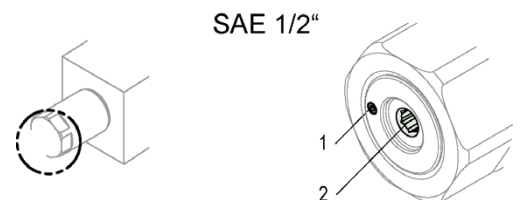

#### 6.4.2 Setting opening start version 2

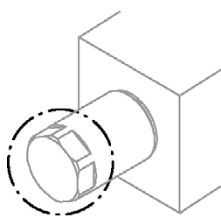

SAE 3/4"-1"

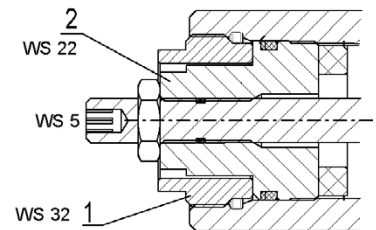
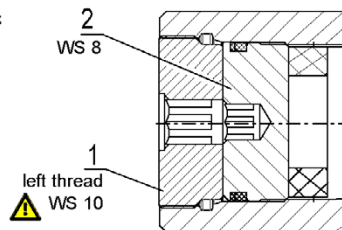

**ATTENTION**

During operation, the valve can heat up to the oil temperature.

- Remove seal (factory status).
- Loosen the AF10 (1) counternut, left-hand thread (Locknut completely screw out at 3/4" + 1" version)
- The opening start of the hose rupture valve must be approximately 0.5 bar above the opening start of the main control unit spool.
- Increase: Turn the set-screw AF8 (2) clockwise.
- Decrease: Turn the set-screws AF8 (2) counter-clockwise.
- An adjustment of 1mm thread corresponds a variation of the opening pressure fo 2,9 bar.
- Tighten the counternut AF10 (1).

## 6.5 Setting Pressure limitation

The pressure limitation of the load control valve is set in the factory according to type code. A setting during startup is not necessary and, for safety purposes, may only be performed by trained technicians using suitable measuring equipment.

The maximum operating pressure of the pressure valve depends on the maximum operating pressure of the machine. Observe the technical data. The pressure valve is in one of the indicated positions.



### ATTENTION

During operation, the valve can heat up to the oil temperature.

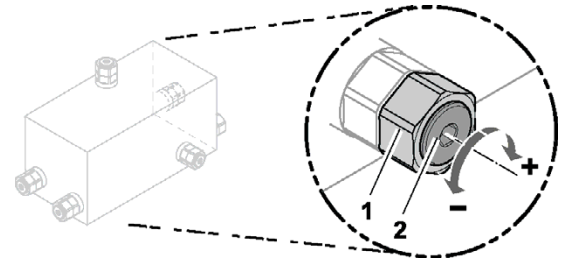

- Undo the counter-nut AF19 (1).
- The operating pressure is set up (see table).
- Increase: Turn the set-screw AF5 (2) clockwise.
- Decrease: Turn the set-screws AF5 (2) counter-clockwise.
- 1 revolution corresponds with 84 bar
- Settings over 420 bar (DIN ISO 6162-2, SAE J518/2 (CODE62)) or 350 bar (DIN ISO 6162-1, SAE J518/1 (CODE61)) are not permissible
- Tighten the counter-nut AF19 (1).

## 6.6 Setting Maximum lowering speed

The setting of the lowering speed limit (if present) also takes place on the spring cap unit. This setting can only be made when the opening pressure has been set correctly.

- Undo the counter-nut (1).
- Screw in the set-screws (4) clockwise until the stop position is detected.
- Turn the set-screw (2) counter-clockwise until the desired maximum lowering speed is reached.
- Setting screw (2) at SAE 1" & SAE 3/4" - 6 mm and at SAE 1 1/4" - 7mm unscrewed means maximum lowering speed, one revolution = 1mm. (Please do not unscrew further)
- By screwing the setting screw (2) in, the load control valve is limited in opening travel, which sets the lowering speed.
- Tighten counter-nut (1), tightening torque 30 Nm.

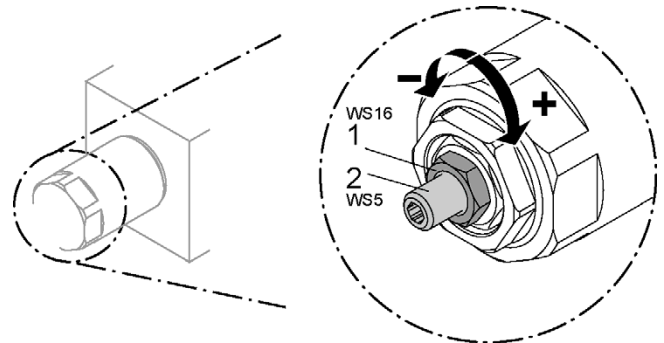

## 7 Dimensions

### 7.1.1 Dimensions LHB-3N

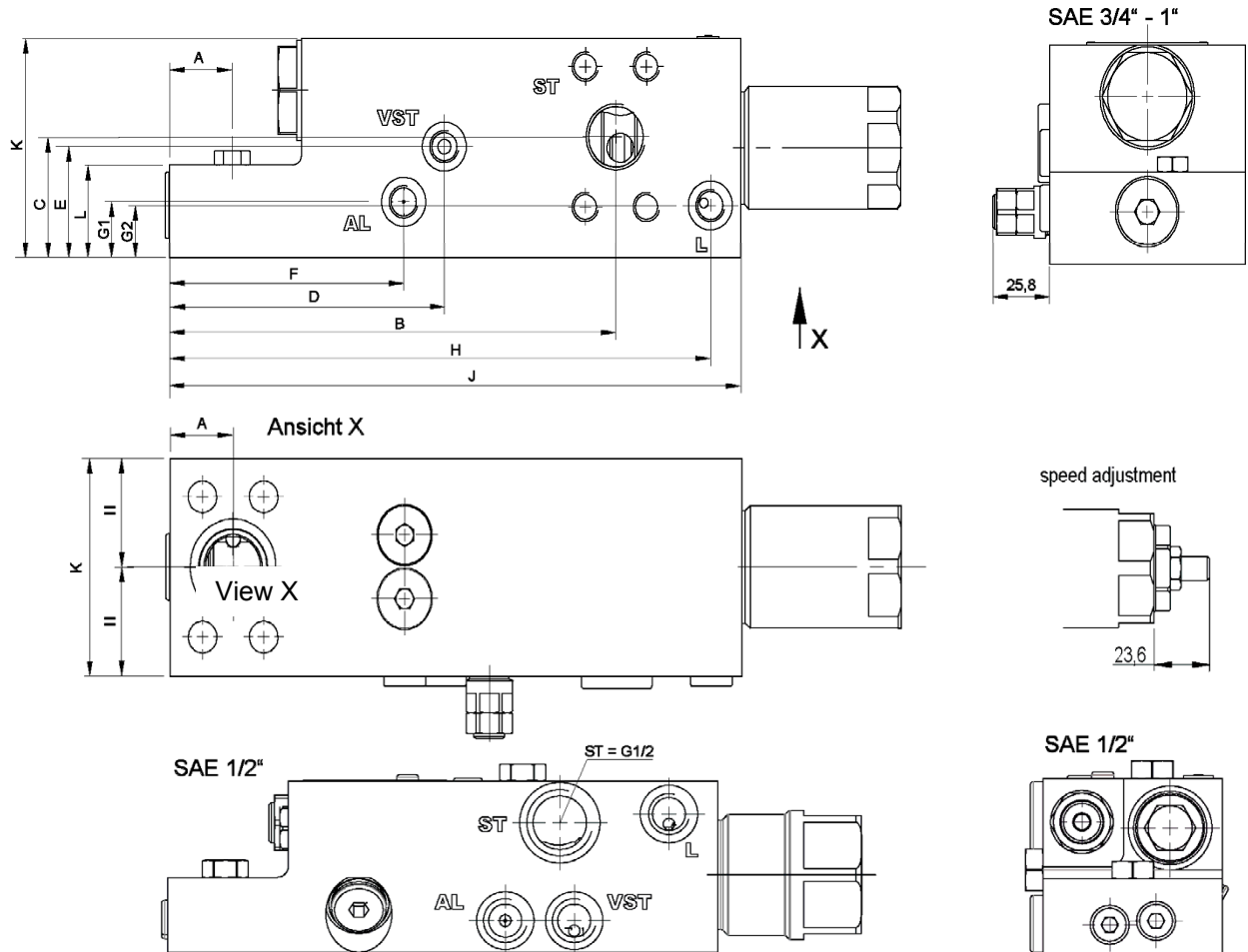

Criterion	Dimension ↑	SAE 1/2"		SAE 3/4"		SAE 1"	
		DIN ISO 6162-2, SAE J518/2 (CODE62)	DIN ISO 6162-1, SAE J518/1 (CODE61)	DIN ISO 6162-2, SAE J518/2 (CODE62)	DIN ISO 6162-1, SAE J518/1 (CODE61)	DIN ISO 6162-2, SAE J518/2 (CODE62)	DIN ISO 6162-1, SAE J518/1 (CODE61)
Z	A (mm)	20	25	25	28.5	28.5	
	B (mm)	136,5	170	170	203	203	
ST	C (mm)	45	39.5	39.5	49.5	49.5	
	D (mm)	141,5	77	77	125	125	
VSt	E (mm)	11	42	42	45.5	45.5	
	F (mm)	117,5	66	66	106.5	106.5	
AL	G1 (mm)	11	14	14	23	23	
	H (mm)	174,5	212	212	246	246	
L	G2 (mm)	48	14	14	21.5	21.5	
	J (mm)	191,5	228	228	260	260	
	K (mm)	50	79.5	79.5	89.5	89.5	
	L (mm)	26	35	35	38	38	

### 7.1.2 SAE dimensions

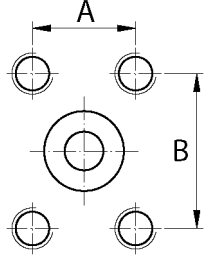
	SAE size	Max. working pressure (bar)	A (mm)	B (mm)
	DIN ISO 6162-1, SAE J518/1 (CODE61)			
	3/4"	350	22.2	47.6
	1"	350	26.2	52.4
DIN ISO 6162-2, SAE J518/2 (CODE62)				
	1/2"	420	18.3	40.5
	3/4"	420	23.8	50.8
	1"	420	27.8	57.2

## 8 Notes, Standards and Safety Requirements

### 8.1 General remarks

- The views in drawings are shown in accordance with the European normal projection variant

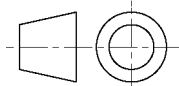

- A comma ( , ) is used as a decimal point in drawings
- All dimensions are given in mm

### 8.2 Standards

The load control valve complies with standards:

- DIN 24093
- ISO 8643
- EN 474

The following standards are to be observed because of the surface temperatures on the load control valve:

- EN 563, Temperatures on surfaces that can be touched.
- EN 982, Safety-technical requirements for fluid-technical systems and their components.

### 8.3 Safety requirements

- WESSEL-HYDRAULIK GmbH guarantees utilization of standard and proven safety principles in accordance with ISO 13849-2: 2003, Tables C.1 and C.2 for the construction of the valve described here.
- WESSEL-HYDRAULIK GmbH has a certified quality management system in accordance with DIN EN ISO 9001.
- The MTTFd value can be adopted from machine manufacturers with 150 years of experience for the described valve!
- Note: The user is therefore responsible for complying with the fundamental and proven safety principles according to ISO 13849-2: 2003, Tables C.1 and C.2 for the implementation and operation of the hydraulic component!

## 9 Accessories